



SERVICE BULLETIN

Classification: BR95-001	Reference: NTB95-046	Date: April 19, 1995
------------------------------------	--------------------------------	-------------------------

1995 MAXIMA REAR BRAKE RATTLE NOISE

APPLIED VEHICLE(S):	1995 Maxima (A32)
APPLIED VIN(S):	JN1CA21DXST049024 to JN1CA21DXST602136
APPLIED DATE(S):	July 18, 1994

SERVICE INFORMATION

Some customers may complain of hearing a rattle noise coming from the rear of the vehicle when driving over bumps or rough roads. If the noise can be reduced or eliminated by a slight application of the parking brake while driving over the road where the noises are produced, the countermeasure kit described below will reduce this incident.

SERVICE PROCEDURE

A countermeasure kit has been developed to minimize the noise produced by the rear brakes while driving over rough roads.

The installation of the kit involves 3 areas:

- Adhesive backed pad retainers.
- Molycoat grease for disc brake pads.
- Brake rubber grease for caliper slide pins.

Installation Instructions

1. Refer to page BR-15 of the 1995 Maxima Service Manual for pad removal procedure.
2. Remove any oil or grease from the torque member in the area that supports the retainer, be careful not to get any solvents on the rubber parts. See figure 1.

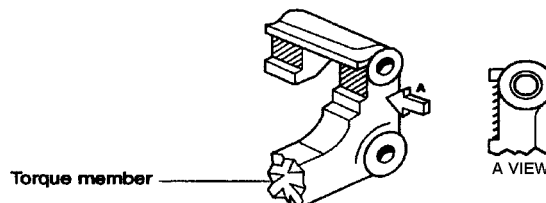

Figure 1

3. Remove the backing paper from the adhesive areas of the retainer. See figure 2.

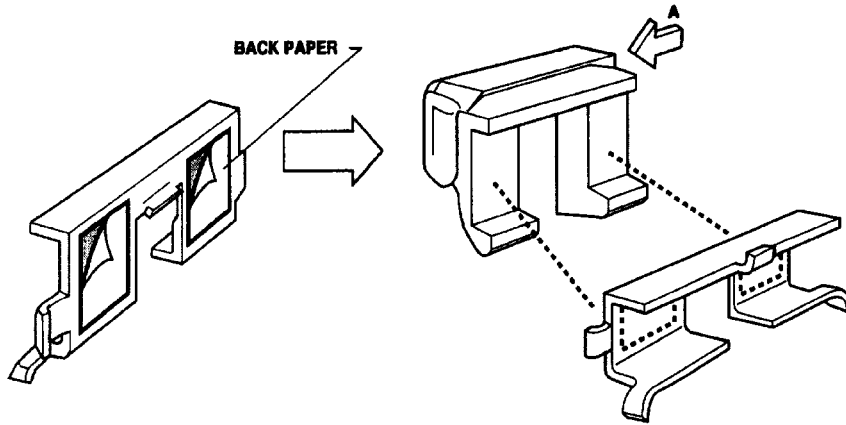

Figure 2

4. Place the retainer onto the torque member, being sure it is seated properly. See figure 3.

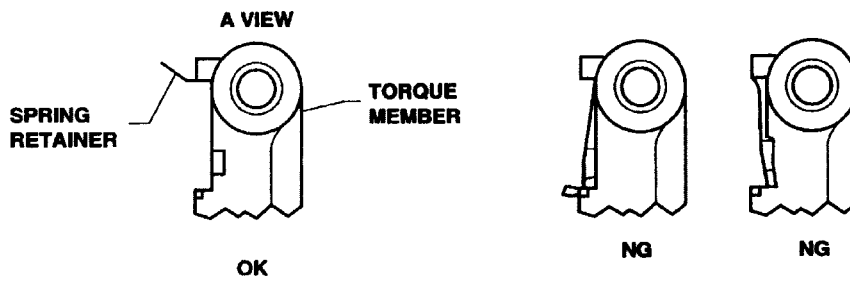

Figure 3

5. Apply molycoat grease to three specific areas of the pad backing plate, be careful not to get any grease on the friction material. See shaded portions of figure 4.

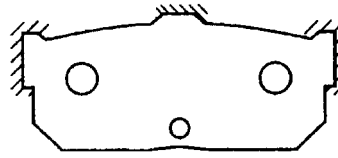

Figure 4

6. Remove the slide pin & boot from the torque member.
7. Inject the supplied brake grease into the slide pin hole.
8. Temporarily, reinstall the slide pin and wipe away any excess grease.
9. Install the brake pads per step #6 on page BR-15 in the Service Manual.
10. Install the caliper assembly, onto the torque member and repeat step #8.
11. Be sure to reinstall the boot on the pin during final assembly.

PARTS INFORMATION

DESCRIPTION	PART #/PFP	QUANTITY
Hardware kit, Rear disc brake pad*	44080-54C29	1 per vehicle

- * The kit includes:
- Molycoat Grease
 - Brake Grease
 - Spring, Retainer and Pads with adhesive tape.

CLAIMS INFORMATION

OPERATION	OP CODE	PNC	SYMPTOM	DIAGNOSIS	FRT
Rpl Pad sets - Both sides	PD19AA	44082	BC	41	0.7 hrs